

BELIZE:

**STANDARDS (BELIZE STANDARDS SPECIFICATION FOR
OXYGEN) (DECLARATION AS A COMPULSORY STANDARD)
ORDER, 2024**

ARRANGEMENT OF PARAGRAPHS

1. Citation.
2. Declaration of Compulsory Standard.
3. Purpose of Compulsory Standard.
4. Commencement.

SCHEDULE.

BELIZE:

STATUTORY INSTRUMENT

No. 62 of 2024

ORDER made by the Minister responsible for the Bureau of Standards, on the recommendation of the Belize Bureau of Standards, in exercise of powers conferred upon him by section 9(2) of the Standards Act, Chapter 295 of the Substantive Laws of Belize, Revised Edition 2020, and all other powers thereunto him enabling.

(Gazetted 15th April, 2024).

WHEREAS, section 9(3) of the Standards Act, Chapter 295 of the Laws of Belize provides that the Minister shall, by publication in the *Gazette*, give at least thirty days' notice of his intention to make an Order declaring a compulsory standard and shall thereby indicate the date on which it is intended that the compulsory standard shall come into force;

AND WHEREAS, a notice of intention to declare the BELIZE SPECIFICATION FOR OXYGEN (BZS 32: 2024) to be a compulsory standard was published in the Belize Gazette dated 13th January 2024;

AND WHEREAS, no objections have been received to the making of the said Order;

NOW, THEREFORE, IT IS ORDERED as follows:-

1. This Order may be cited as the

Citation.

STANDARDS (BELIZE STANDARDS SPECIFICATION FOR OXYGEN) (DECLARATION AS A COMPULSORY STANDARD) ORDER, 2024.

**Declaration of
Compulsory
standard.
Schedule.**

2. The Belize Standard (BZS 32: 2024 SPECIFICATION FOR OXYGEN), the full text of which appears in the Schedule hereto, is hereby declared to be a compulsory standard.

**Purpose of
Compulsory
Standard.**

3. The standard referred to in paragraph 2 is intended primarily–

- (a) to protect the consumer or user against danger to health or safety;
- (b) to ensure quality in goods produced for home use or for export;
- (c) to prevent fraud or deception arising from misleading advertising or labelling; and
- (d) to require adequate information to be given to the consumer or user.

Commencement.

4. This Order shall come into effect on the 15th day of April 2024.

SCHEDULE*[paragraph 2]***BEIZE STANDARD
SPECIFICATION FOR OXYGEN**

0 FOREWORD

- 0.1 This standard provides a description of oxygen characteristics, safety, storage and handling practices, when it is used for medical or industrial applications.
- 0.2 In preparing this draft, assistance was received from the following documents:
- a) CGA G-4 – Oxygen, Eleventh Edition (Compressed Gas Association);
 - b) CGA G-4.3 - Commodity Specification for Oxygen, Eighth Edition (Compressed Gas Association);
 - c) USP 29 - United States Pharmacopeia and National Formulary (USP–NF);
 - d) 21 CFR - Title 21 of the U.S. Code of Federal Regulations, (21 CFR) Part 3.

1. SCOPE

- 1.1 This standard specifies minimum requirements for gaseous and liquid oxygen obtained by the air liquefaction process which is commonly used in medical and industrial applications.
- 1.2 This standard also provides information regarding oxygen properties and safe handling practices.
- 1.3 It is intended for oxygen importers, suppliers, distributors, fillers and users.

2 NORMATIVE REFERENCES

The following referenced documents are indispensable for the application of this document. For dated references, only the edition cited applies. For undated references, the latest edition of the referenced document (including any amendments) applies.

- a) BZS 1: Part 8 - Belize Standard Specification for Labelling Part 8: Labelling and Marking of Medical Gas Cylinders.
- b) CGA G-4.3 - Commodity Specification for Oxygen.
- c) CGA G-4 - Oxygen, Eleventh Edition (Compressed Gas Association).
- d) USP 29 - United States Pharmacopeia and National Formulary (USP–NF).
- e) 21 CFR - Title 21 of the U.S. Code of Federal Regulations, (21 CFR) Part 3.
- f) 49 CFR - Title 49 of the U.S. Code of Federal Regulations (49 CFR) Parts 100-199.

3 TERMS AND DEFINITIONS

For the purpose of this standard, the following definitions of terms shall apply.

- 3.1 **Container** means a portable compressed gas cylinder and liquid container made in accordance with Title 49 of the U.S. Code of Federal Regulations (49 CFR) Parts 100-199.
- 3.2 **Cryogenic vessel** means a container designed to contain liquefied gas at an extremely low temperature.
- 3.3 **Cylinder** means a container designed to contain gas at a high pressure.

- 3.4 **Distributor** means a person or firm who markets filled medical gas cylinders.
- 3.5 **Lot** means an amount of a product produced during a period with the same characteristics, identified by a specific code.
- 3.6 **Manufacture** means all operation of purchase of materials and products, Production, Quality Control, release, storage, distribution of medicinal products and the related controls.
- 3.7 **Manufacturer** means a person or firm who produces, fills or relabels medical gas cylinders or containers.
- 3.8 **Oxygen** means a molecule that exists at atmospheric temperatures and pressures as a colorless, odorless, tasteless gas.
- 3.9 **Packaging** means all operations, including filling and labelling, which a bulk product has to undergo in order to become a finished product.
- 3.10 **Pressure relief device** means a device consisting of a frangible disk designed to burst under excessive pressure, or a combination disk backed with fusible metal with a low melting point designed to melt and release the gas in case of fire.
- 3.11 **Production** means all operations involved in the preparation of a medicinal product, from receipt of materials, through processing and packaging, to its completion as a finished product.
- 3.12 **Quality Verification Level (QVL)** means a parameter that specifies the maximum number of impurities (also termed limiting characteristics) that can be present.

4 GENERAL REQUIREMENTS

4.1 Description

- a) The outstanding property of oxygen is its ability to sustain life and to support combustion. Although oxygen is nonflammable, materials that normally do not burn in air can burn in an oxygen-enriched atmosphere.
- b) Materials that burn in air will burn more vigorously and at a higher temperature in an oxygen-enriched atmosphere.
- c) Some combustibles such as oil burn in oxygen with near explosive violence if ignited by flame, impact, or some other energy source. As a result of these properties, caution shall be exercised, and precautions taken when entering areas or confined spaces where an oxygen-enriched atmosphere can exist.
- d) As a gas, oxygen is 1.1 times heavier than air. It can be compressed and cooled to a pale blue liquid that, under atmospheric pressure, boils at $-297.3\text{ }^{\circ}\text{F}$ ($-182.9\text{ }^{\circ}\text{C}$). As a liquid (at normal boiling point), oxygen is 1.14 times heavier than water. When heated above its critical temperature of $-181.4\text{ }^{\circ}\text{F}$ ($-118.6\text{ }^{\circ}\text{C}$), oxygen can exist only as a gas, regardless of the pressure that is exerted upon it.
- e) Oxygen is classified by the U.S. Department of Transportation (DOT) as a non-flammable, oxidizing gas.

4.2 Manufacture

- a) The primary method of manufacturing oxygen is by fractional distillation after the liquefaction of air. Improved efficiency in utilization has led to a generally recognized industry standard of purity, which exceeds the 99% required by the United States Pharmacopeia and National Formulary (USP-NF).
- b) Oxygen of lower purity can be used in some chemical and metallurgical processes. Other methods of manufacturing

oxygen include pressure swing adsorption, vacuum swing adsorption, membrane separation, electrolysis, and chemical reaction. These processes produce oxygen at lower purities than that obtained by fractional distillation at cryogenic temperatures.

5 CLASSIFICATION

5.1 Types

Oxygen is classified according to its type and grade of quality. There are two types:

- a) Type I: gaseous oxygen.
- b) Type II: liquid oxygen.

5.2 Typical Commercial uses:

- a) The main uses of oxygen stem from the life-sustaining and combustion-supporting properties of the gas. It is also used to sustain life in high altitude aviation, deep sea diving, and similar applications.
- b) The industrial uses of oxygen include its use with acetylene or other fuel gases in such processes as metal cutting, welding, hardening, scarfing, cleaning, and dehydrating. Oxygen is also used in the manufacture of steel and in various chemical processes and as an oxidizer for fuels in rockets and missiles. Table 1 shows the use of gas according to its type.

Table 1 – Typical uses for oxygen

QVL	TYPE I
A	Medical USP, food and beverage applications
C	Industrial welding, cutting, oxidation processes

QVL	TYPE II
A	Medical USP, food and beverage applications
B	Industrial welding, cutting, oxidation processes

5.3 Quality Verification Level (QVL)

- a) Table 2 presents the component maximum levels in parts per million (ppm [v/v]), unless otherwise shown, for the Quality Verification Levels (QVL) of oxygen. The absence of a value in a listed QVL does not mean that the limiting characteristic is or is not present but merely indicates that the test is not required for compliance with the specification.
- b) By standard practice, the supplier ensures the QVL of oxygen. If otherwise required, alternative control procedures are described in this standard. Other control procedures not listed in this publication are acceptable if agreed to by the supplier and the customer.

WARNING: *Oxygen accelerates combustion. Use equipment cleaned for oxygen service. High concentrations of oxygen can be harmful if inhaled over long periods of time.*

Table 2—Quality Verification Levels (QVL)

CHARACTERISTICS	MAXIMUM LEVELS FOR TYPE I (GAS)		MAXIMUM LEVELS FOR TYPE II (LIQUID)	
	A	C	A	B
Oxygen min % v/v	99	99.5	99	99.5
Water (ppm)		50		6.6
Dew Point (°F)		-55		-82

5.4 Oxygen USP

- a) Oxygen USP is classified as a drug and shall be labeled in accordance with the appropriate food and drug regulations.

- b) The oxygen USP label denotes dual application based on dose and duration of the device. For emergency use by properly trained personnel, a prescription is not required.
- c) The device shall be labeled in accordance with FDA regulations, Title 21 of the U.S. *Code of Federal Regulations*, (21 CFR) Part 3. The device shall consist of pressure-reducing equipment capable of maintaining a constant flow of at least 6 L of oxygen per minute for a minimum of 15 minutes, a contents indicator, and a mask or other means of administering oxygen to the patient. For all other medical applications, the statement “Rx only” or Rx only symbol is required.

6 QUALITY VERIFICATION SYSTEM

6.1 Production qualification tests

This test is an analysis performed on the product to ensure the reliability of the production facility to supply oxygen of the required QVL. This production qualification may be verified by the analytical records of product from the supplier or, if required, by analysis of representative samples of the product from the facility at appropriate intervals. Production qualification tests may be performed by the supplier or by an external laboratory.

6.2 Analytical requirements of the production qualification tests

- a) Analytical requirements of the production qualification tests include the determination of all limiting characteristics of air.
- b) To comply with the General Notices requirements of the *U.S. Pharmacopeia* and *National Formulary (USP–NF)*, tests suitable for detecting the occurrence of other impurities, the presence of which is inconsistent with applicable

manufacturing practice or good pharmaceutical practice, should be used in addition to the tests provided in the U.S. Pharmacopeia (USP) monograph.

6.3 Lot acceptance tests

Lot acceptance tests are analyses performed on the oxygen in the shipping container or a sample thereof that is representative of the lot.

6.4 Lot definitions

Examples of a lot include, but are not limited to, the following:

- a) oxygen supplied during a specific time period (for example, one continuous work shift, daily, weekly, etc.);
- b) oxygen supplied in one shipment;
- c) oxygen supplied in the container(s) filled on one manifold at the same time; and
- d) oxygen supplied or containers filled during an uninterrupted filling sequence,

Other definitions may be used.

7 SAMPLING

7.1 Sample size

The number of samples per lot may vary. At least one sample per lot shall be analyzed. The quantity of oxygen in a single sample container should be sufficient to perform the analyses for all of the limiting characteristics. If a single sample container does not hold enough oxygen to perform all of the analyses for the required QVL, additional samples

from the same lot shall be taken under similar conditions.

7.2 Gaseous samples

Gaseous samples shall be representative of the gaseous oxygen supply. Samples shall be obtained in accordance with one of the following:

- a) By filling the sample container and delivery containers at the same time, on the same manifold, and in the same manner.
- b) By withdrawing a sample from the supply container through a suitable connection into the sample container.
 - i. No regulator shall be used between the supply and the sample container (a suitable purge valve is permissible);

CAUTION: For safety reasons, the sample container and sampling system shall have a rated service pressure at least equal to the pressure in the supply container.

- c) By connecting the container being sampled directly to the analytical equipment using suitable pressure regulation to prevent over pressurizing this equipment; or
- d) By selecting a representative container from the containers filled in the lot.

7.3 Liquid samples

Liquid samples shall be representative of the liquid oxygen supply. Samples shall be obtained by withdrawing a sample directly through an analytical filter system.

8 ANALYTICAL PROCEDURES

8.1 Parameters of analysis

The parameters for analytical techniques contained in this section are:

- a) percent (v/v) = parts per hundred by volume;
- b) ppm (v/v) = parts per million by volume;
- c) Water/dew point is expressed in ppm (v/v) and °F at 1 atm, abs (101 kPa, abs);
- d) Calibration gas standards containing the applicable gaseous components are required to calibrate the analytical instruments used to determine the limiting characteristic levels of oxygen;
- e) Analytical equipment shall be operated and properly calibrated in accordance with the manufacturer's instructions;
- f) Specific measurement of odor in oxygen is impractical. The presence of a pronounced odor should render the oxygen unsatisfactory;
- g) USP refers to the test requirements for oxygen contained in the most recent edition of the *USP-NF*; and
- h) Other analytical methods not listed in this specification are acceptable if agreed upon between the supplier and the customer.

8.2 Percent oxygen

The percent oxygen shall be determined by one of the following procedures:

- a) By a paramagnetic type analyzer. The analyzer shall be calibrated at appropriate intervals by use of calibration gas standards. Refer to *USP-NF*. For

nondigital instruments, the range used should be no greater than 10 times the difference between the specified minimum percent oxygen and 100%. Thus, for 99.5% minimum oxygen, the analyzer should have a maximum range of 5% impurity or from 95% to 100% oxygen;

- b) By a thermal conductivity type analyzer. The analyzer shall be calibrated at appropriate intervals by use of calibration gas standards. The range used should be no greater than 10 times the difference between the specified minimum percent oxygen and 100%. Thus, for 99.5% minimum oxygen, the analyzer should have a maximum range of 5% impurity, or from 95% to 100% oxygen; or

NOTE: The principle of operation for the thermal conductivity analyzer is bipolar in nature. It is normally used only to measure the composition of binary mixtures. An argon-in-oxygen gas standard is normally used. Where the possibility of a contaminant other than argon (e.g., nitrogen) can exist in the oxygen, the use of a thermal conductivity analyzer may not be appropriate.

- c) By determining the amount of aggregate impurities using the methods in the following sections. The percent oxygen is the value obtained when this amount, expressed as mole percent, is subtracted from 100%.

8.3 Odor

The odor shall be determined by sniffing a moderate flow of oxygen vapor from the container being tested.

CAUTION: While performing this procedure, do not place face directly in front of valve or beaker. Instead, cup the hand and

bring some of the gas being vented toward the nose.

8.4 U.S. Pharmacopeia tests

USP tests shall be performed as specified in the USP–NF.

8.5 Water content

The water content shall be determined by one of the following procedures:

- a) By an electrolytic hygrometer having an indicator graduated in ppm (v/v) on a range that is no greater than 10 times the specified maximum moisture content. The analyzer shall be operated in a manner that accurately measures the limiting characteristics as defined in Table 1;
- b) By a dew point analyzer in which the temperature of a viewed surface is measured at the time moisture condensation first begins to form;
- c) By a piezoelectric oscillating quartz crystal hygrometer. The analyzer shall be operated in a manner that accurately measures the limiting characteristic as defined in Table 2; or
- d) By a metal oxide capacitor-equipped analyzer on a range that is no greater than 10 times the specified maximum moisture content. The analyzer shall be operated in a manner that accurately measures the limiting characteristics as defined in Table 2.

9 OXYGEN CYLINDERS AND CONTAINERS

9.1 General

- a) If oxygen is transported in containers at a pressure exceeding 40.6 psia (280 kPa, abs) at 68 °F (20 °C), it

shall be shipped in containers that meet DOT specifications.

- b) Cylinder specifications require, among other things, that the containers pass certain periodic requalification tests, and that the containers are protected by appropriate pressure relief devices (Pressure relief devices).
- c) Gaseous oxygen is commonly transported in seamless steel cylinders constructed to TC/DOT Specifications 3A or 3AA cylinders or UN pressure receptacles, with nominal capacities of up to 330 scf (9.34 m³).³ Higher pressure steel cylinders with greater capacities are also available. Oxygen may also be transported in disposable (Specification 39) or aluminum (Specification 3AL) cylinders.
- d) Liquid oxygen may be shipped in TC/DOT-4L insulated cylinders (commonly called liquid cylinders). A commonly used Specification 4L cylinder has an approximate equivalent capacity of 5000 scf (142 m³) of gaseous oxygen. Specification 4L cylinders having greater capacity are available.
- e) In addition, oxygen may be shipped in cylinders made to a DOT special permit or to any ISO Standard.

9.2 Valve outlet and connection

- a) Container valve connections that do not fit shall not be used. Threads on regulator connections or other auxiliary requirements shall match those on the container valve outlet. The valve outlet connection shall conform to recognized standards.
- b) The threads on a cylinder valve outlet, as well as on regulators and other ancillary equipment, shall be examined prior to connection to ensure they are clean and undamaged.

Table 3: Valve connection for Oxygen Cylinder and Containers

Oxygen Gas rating	CGA Standard
Up to 500 psi (3450 kPa)	601
Up to 3000 psi (20 680 kPa) Threaded	540, 540R
(Type E) Yoke	870
3001 to 3500 psi (20 690 to 24 130 kPa)	577
3501 to 4700 psi (24 140 to 32 400 kPa)	701
Cryogenic liquid withdrawal	440
Ultra-high integrity	714

9.3 Pressure relief devices

- a) A pressure relief device is a pressure and/or temperature-activated device used to prevent the pressure in a normally charged cylinder from rising above a predetermined maximum, thereby preventing rupture of the cylinder when subjected to a standard fire test as required by 49 CFR 173.301(f)(1) or clause 4.3.2 of CSA B340 as adopted by 5.10(1) of the TC regulations [1, 2, 4].
- b) Oxygen cylinders are required to be equipped with pressure relief devices. Cryogenic vessels may be equipped with spring-loaded pressure relief valves that reseal when the pressure drops to a preselected value.
- c) A Type CG-1 PRD is a rupture disk device that functions by inlet static pressure actuating the rupture disk by bursting in tension or shear at a predetermined pressure to permit the discharge of gas.
- d) When a rupture disk device is used as a PRD on a compressed gas cylinder, the rated burst pressure of the disk when tested at the specified design temperature within the range of 60F to 160F (15.6C to 71.1C) shall not exceed the minimum required test pressure of the cylinder with which the disk is used.

9.4 Filling limits

- a) Because of the characteristics of any gas confined in a closed container to increase in pressure with rising temperature, the possibility always exists that a cylinder charged with gas at a safe pressure at normal temperature could reach a dangerously high pressure at high temperatures. To prevent this with normal usage, regulations limit the amount of gas that may be charged into a cylinder.
- b) TC/DOT-3A, TC/DOT-3AA, TC/DOT-3AL, and TC/DOT-39 cylinders shall not be filled to a pressure greater than the stamped service pressure at 70 °F (21.1 °C). TC/DOT-3A and TC/DOT-3AA cylinders stamped with a plus mark (+) after the last test date may be filled to a pressure 10% greater than the stamped service pressure.
- c) At pressures greater than 25.3 psi (174 kPa), TC/DOT-4L cylinders shall be filled by weight.

9.5 Retesting

- a) Specification 3A, 3AA, and 3AL cylinders, UN and ISO receptacles shall be periodically retested. Periodic retesting of Specification 4L welded insulated liquid cylinders is not required. Specification 39 cylinders shall not be refilled and hence require no retest. Retesting of 3E cylinders is not required. Cylinder retesting shall be performed only by DOT authorized retesters holding a valid RIN as prescribed in 49 CFR parts 100 – 199.
- b) Cylinders that have been in a fire shall be removed from service and shall not be returned to service. Specification 3AL cylinders that are exposed to fire or temperatures above 350 °F (177 °C) shall be removed from service and condemned. Specification 4L cylinders that are in a fire shall be removed from service and condemned.

- c) Cylinders showing any type of damage that jeopardizes their integrity and the safe transportation of the gas or liquid content, shall be removed from service, and condemned.
- d) Records shall be kept giving data showing the results of the tests made on all cylinders, and each cylinder passing the test shall be plainly and permanently stamped with the month and year of the test as well as the retester's identification number. Dates of previous tests shall not be obliterated.
- e) Cylinder marking shall comply with DOT requirements established in 49 CFR, and shall not be removed or changed, except as provided in applicable regulations.

9.6 Labelling

- a) Oxygen manufactured, imported, sold or offered for sale in containers shall comply with the Belize Standard Specification for Labelling Part 8: Labelling and Marking of Medical Gas Cylinders.
- b) In addition to marking of the proper shipping name and identification number on a cylinder, a 100 mm (3.9 in) diamond (square-on-point) green label (designating a nonflammable gas) having the number 2 in the lower corner plus a 100 mm (3.9 in) diamond (square-on-point) yellow label (designating a subsidiary risk as an oxidizer) having a 5.1 in the lower corner be attached to each cylinder containing oxygen when transported by common carrier.
- c) In lieu of using the two 100 mm (3.9 in) diamond (square-on-point) labels, the use of a single 100 mm (3.9 in) diamond (square-on-point) yellow label (designating an oxidizer) having the number 2 in the lower corner and having the mandatory word OXYGEN printed on it is permitted.

- d) The proper shipping name for gaseous oxygen and product identification number is Oxygen, UN 1072. For liquid oxygen it is Oxygen, Refrigerated Liquid, UN 1073.

9.7 Tank cars

- a) High pressure gaseous oxygen may be transported in tank cars complying with the safety practices related to gas industry.
- b) Liquid oxygen is transported in vacuum-insulated tank cars at pressures less than 25.3 psi (174 kPa) in tank cars class AAR 204W and at pressures up to 60 psi (413.7 kPa) in tank cars class TC/DOT 113A90W.
- c) Shipping papers shall include proper shipping name.
- d) Marking the container with the proper DOT/TC and identification number, and incident reporting method shall be considered according to emergency response guidebook information.
- e) It is prudent, however, to mark tank cars transporting liquid oxygen on each side with the words OXYGEN, REFRIGERATED LIQUID.

10 HIGH PRESSURE OXYGEN CYLINDERS

10.1 Guidelines for safe storage

- a) Cylinders should be stored in a designated location.
- b) Cylinders shall not be placed near flammable material, especially oil, grease, or any other readily combustible substance.
- c) Oxygen cylinders shall not be placed where oil or other hydrocarbons can drip on the cylinder, its valve, or other attachments.

- d) Cylinders shall not be stored in an acetylene generator room or near cylinders containing acetylene or other flammable gases. Unless separated by a distance of 20 ft (6.1 m), there shall be a non-combustible barrier at least 5 ft (1.5 m) high with a fire-resistance rating of at least 1/2 hours between the oxygen cylinders and the acetylene or other flammable gas cylinders.
- e) Cylinders should not be stored above 125 °F (51.7 °C). Cylinders should never be allowed to reach a temperature exceeding 125 °F (51.7 °C) because of the rise in pressure in the cylinder with increasing temperature. Therefore, cylinders should never be placed near furnaces, radiators, or any other source of heat.
- f) Cylinders should be protected from abnormal mechanical shock, which is liable to damage the cylinder, valve, or pressure relief device.
- g) Cylinders shall be protected from heavy moving objects striking them or falling on them.
- h) Cylinders shall not be stored in areas (i.e., elevators, gangways, etc.) where the cylinders can fall more than half of their height.
- i) Cylinders in storage shall be stored standing upright where they are not likely to be knocked over, or the cylinders shall be secured.
- j) Small cylinders may be stored in a horizontal position if the cylinder is installed in a holder or cradle designed to secure the cylinder.
- k) Valve protection caps, when provided, shall be in place and fastened hand-tight, except when cylinders are in use or connected for use.

- l)* Cylinders should be protected from tampering. Medical oxygen cylinders shall be protected from tampering.
- m)* Empty and full cylinders should be stored separately and empty cylinders should be marked to avoid confusion.
- n)* Cylinders should be stored in dry, well-ventilated locations to prevent accidental movement.
- o)* Cylinders should not be stored near salt or other corrosive chemicals or fumes. Rusting will damage the cylinders and can cause the valve protection caps to stick.
- p)* Cylinders should be stored on a suitable foundation such as concrete or steel grating.
- q)* Valves shall be closed on all cylinders not in use.

10.2 Guidelines for safe handling

- a)* Oxygen cylinders or apparatus shall not be handled with hands or gloves contaminated with oil or other hydrocarbons;
- b)* Cylinders shall only filled by a certified supplier;
- c)* Never tamper with, attempt to repair, paint, or alter cylinders, valves, or Pressure relief devices. Polishing and cleaning agents should never be applied to the valve since they can contain chemicals not compatible with the valve material or the gas in the cylinder;
- d)* Cylinders shall not be placed where they can become part of an electric circuit. When electric welding, precautions shall be taken to prevent striking an arc against a cylinder;

- e) Markings stamped on cylinders shall not be tampered with except as provided by DOT authorized requalifier;
- f) Markings used for the identification of contents of cylinders shall not be defaced or removed. This applies to labels, decals, tags, stenciled marks, and the diamond-shaped yellow label, if attached;
- g) Notify the owner of the cylinder giving details and the cylinder number if any condition occurs that allows a foreign substance to enter the cylinder or valve;
- h) Cylinders shall not be used as rollers, supports, or for any purpose other than as intended by the supplier;
- i) It is sometimes necessary to move cylinders by crane or derrick. Lifting magnets, slings of rope or chain, or any other device on which the cylinders themselves form a part of the carrier shall not be used for hoisting oxygen cylinders. Instead, when a crane is used, a platform, cage, or cradle shall be provided that protects the cylinders from damage and keeps them from falling out;
- j) A suitable hand truck should be used with the container properly secured to the device;
- k) Cylinders shall not be transported lying horizontally on forklift trucks with valves overhanging in a position to collide with stationary objects. Whenever a forklift is used to transport cylinders, the cylinders shall be secured to prevent them from falling off;
- l) Cylinders shall not be dragged from place to place;
- m) Valves shall always be closed and protective caps shall be in place when appropriate before cylinders are moved;

- n) Cylinders should not be transported in the trunks of automobiles. They should be transported upright and secured properly;
- o) Cylinders may be transported and used in a horizontal position in ambulances and emergency vehicles if the cylinder is installed in a holder or cradle that is designed to secure the cylinder and protect the valve and regulator; and
- p) Small cylinders, such as those used in medical applications, are not equipped with valve protection caps or guards. These cylinders are susceptible to valve damage if dropped. Special precautions shall be taken when handling these types of cylinders. If a cylinder is dropped and the valve is damaged, the cylinder should be returned to the supplier unused. Damaged valves should be replaced before refilling.

10.3 Guidelines for safe use

- a) Never refer to gaseous oxygen as air. Call it by its proper name, oxygen. The chemical properties of pure oxygen are substantially different from those of air and dangerous situations can result if the two are confused.
- b) Never use oxygen as a substitute for compressed air. It is dangerous to use oxygen for pneumatic tools, to start diesel engines, for imposing pressure in oil reservoirs, for paint spraying, for blowing out pipelines, etc. Using oxygen in such a manner can result in fire or explosion.
- c) Never permit oil, grease, or other readily combustible substances to come in contact with oxygen cylinders, valves, regulators, gauges, and fittings. Oil and oxygen can combine with explosive force if ignited by flame, impact, or some other energy source.
- d) Keep sparks and flame away from cylinders and never allow a torch flame to come in contact with cylinders,

valves, or pressure relieve devices. Should the valve outlet of a cylinder become clogged with ice, thaw with warm (not boiling) water.

- e) Never lubricate oxygen valves, regulators, gauges, or fittings with oil or any other combustible substance. Approved oxygen compatible lubricants and greases for the appropriate service may be used when needed.
- f) Use only equipment cleaned for oxygen service.
- g) Use only cylinders marked in accordance with applicable DOT, UN or ISO regulations or standards.
- h) Never use manifolds for oxygen cylinders unless constructed with the advice of a qualified engineer. Do not supply oxygen by a system of shop piping without consulting your oxygen supplier for recommendations regarding construction, materials, and cleaning requirements.
- i) Never attempt to mix gases in an oxygen cylinder. Oxygen should only be transferred by experienced and properly instructed persons. The user should never attempt to transfer oxygen from one cylinder to another.
- j) Compressed gases should be handled only by experienced and trained persons. The user shall first identify the product within the cylinder from the label or stencil on the cylinder before use.
- k) If the cylinder is not labeled to show the product contained, return the cylinder to the supplier unused.
- l) Ensure that there is no oil or grease on hands or gloves, cylinders, valves, regulators, gauges, and fittings. Oil and oxygen can combine with explosive violence if ignited.

10.4 Disposition of empty cylinders

When high pressure oxygen cylinders have been emptied, this procedure should be followed to ensure their prompt return to the supplier:

- a) Close the cylinder valve;
- b) Replace the valve protection cap or outlet plug where provided;
- c) Mark or tag the cylinder: EMPTY; and
- d) Return the cylinders promptly to the supplier in accordance with the supplier's instructions.

11 LIQUID OXYGEN

11.1 Guidelines for safe storage, handling and use

- a) Liquid oxygen cylinders are double-walled pressure vessels usually of 45 gal (170.3 L) capacity or greater and should not be confused with double-walled atmospheric pressure liquid oxygen containers commonly referred to as dewars.
- b) Liquid oxygen is an oxidizer. Adapters shall not be used for filling or using connections. Only certified filler may fill liquid cylinders, considering hazard involved in the process.
- c) Containers with liquid oxygen shall not be kept in confined or poorly ventilated areas as potentially hazardous concentrations of oxygen gas can collect temporarily because of venting from containers.
- d) Because of the extremely low temperature of liquid oxygen (-297.3 °F [-182.9 °C]), the physical properties of materials that come in contact can be greatly altered. This fact shall be considered wherever

liquid oxygen is handled. Appropriate personal protective equipment (PPE) should always be worn:

- i.* Goggles (or preferably face shields), gloves, and aprons shall be worn.
 - ii.* Leather gloves loose enough to permit quick removal are recommended.
 - iii.* High-top shoes with cuffless trousers worn outside are desirable.
 - iv.* Any clothing that is splashed with liquid oxygen should be removed and promptly aired for at least 1 hour away from any sources of ignition
- e)* Liquid oxygen should never be allowed to come in contact with skin. Severe frostbite can result.
- f)* Frostbite, which causes an effect on the skin similar to a burn, also results if contact is made with uninsulated pipe or vessels containing liquid oxygen. Seek prompt medical treatment for frostbite injuries.
- g)* Liquid oxygen is stored and shipped in specially designed and well-insulated containers that maintain the pressure of the vapor above the liquid at either atmospheric or a low positive pressure.
- h)* Equipment and techniques used in liquid oxygen distribution are usually determined by the requirements of the user's installation. Users should be instructed by suppliers in the use and operation of the supply or storage unit.
- i)* Liquid oxygen shall be handled or used only by persons instructed in the properties and hazards of liquid oxygen. Users shall identify the product from the label on the liquid cylinder or container before use. If the cylinder or container is not labeled to show the product contained, return the cylinder or container to the supplier unused.

- j) Liquid oxygen equipment shall be kept clean, and organic or combustible material shall not be allowed to come in contact with the liquid. Many such materials react violently with oxygen under certain conditions of temperature and pressure.
- k) Liquid oxygen shall be transported only in suitable containers that permit the escape of vapors to control the pressure that can build up in the container.
- l) Fire, sparks, and other sources of ignition should be kept away from the area exposed to the vapors resulting from evaporation. Concentrations of the vapor shall be prevented by ample ventilation.
- m) A small quantity of liquid produces a large volume of oxygen gas at atmospheric pressure (the volume expansion on evaporation equals 856 to 1). Therefore, all storage containers shall be provided with pressure relief devices unless the container (as with small vacuum-insulated bottles or flasks) is vented to the atmosphere.
- n) All pipelines or vessels in which liquid oxygen can be trapped between closed valves shall be equipped with pressure relief devices. In cases where liquid oxygen can be trapped in any valve cavity, a means of venting shall be provided.
- o) All pressure relief devices shall be placed or protected so water does not collect or freeze on them, which can interfere with their proper operation.

11.2 Moving liquid cylinders

- a) Liquid cylinders or containers have an inner suspension system designed to minimize heat leak. They should never be subjected to shocks, falls, or impacts.
- b) Liquid cylinders shall always be kept upright.

- c) Full liquid cylinders are very heavy and shall only be moved using equipment designed for that purpose (e.g., a four-wheeled cart).
- d) Rolling full cylinders or containers is extremely hazardous because if the cylinder or container falls, the inner container can fail allowing liquid oxygen into the annular space where it would vaporize rapidly and build up pressure that can cause an explosive rupture of the outer shell.

11.3 Storage

- a) Liquid cylinders or containers shall be stored in a well-ventilated area, preferably outdoors.
- b) Heat leak into liquid cylinders can gradually increase the internal pressure of a cylinder or container until the pressure relief valve setting is reached. Oxygen vapor will then be vented. Ventilate the storage area so the oxygen concentration does not exceed 23.5%.
- c) Oxygen cylinders or containers shall not be stored near flammable or combustible materials.
- d) Liquid oxygen cylinders or containers are dependent upon the vacuum in the insulation space between the double walls to provide the required degree of insulation. If this vacuum is lost, excessive amounts of gaseous oxygen will vent through the pressure relief devices. In such cases, the cylinder or container should be immediately moved outdoors and the cylinder or container supplier notified.

11.4 Use

- a) When using liquid oxygen cylinders, only regulators, valves, hoses, and other equipment designed and cleaned for oxygen service shall be used.

- b) If the cylinder is not labeled to show the product contained, return the cylinder or container to the supplier unused.
- c) A liquid oxygen cylinder is equipped with a liquid valve, a vent valve, and pressure relief devices. Other items such as a gas-use valve, a pressure gauge, a liquid level gauge, and various regulators can be supplied depending on the design of the cylinder or container and its intended use. The gas-use valve, the liquid valve, the liquid level gauge, and the pressure gauge are the only devices intended for customer use.
- d) Ensure that the threads on regulators or other unions correspond to those on cylinder or container valve outlets. Never force connections that do not fit. A proper connection goes together smoothly. Never interchange oxygen regulators, hose, or other appliances with similar equipment intended for use with other gases. **DO NOT USE ADAPTERS.**
- e) The gas-use valve is used for withdrawing gaseous oxygen from the liquid oxygen cylinder or container. Suitable safety equipment should be used including, as a minimum, eye protection as required for handling high pressure gas.
- f) Oxygen systems shall be cleaned and inspected to ensure that no combustible materials remain in the system.

11.5 Disposition of empty cylinders or containers

When liquid oxygen cylinders or containers have been emptied use the following procedure to ensure their prompt return to the supplier:

- a) Close all valves;
- b) Replace all outlet protective devices;

- c) Tag or mark the cylinder or container EMPTY; and
- d) Return the cylinder or container promptly to the supplier in accordance with the supplier's instructions.

12 CYLINDER AND CONTAINER STORAGE REQUIREMENTS IN HEALTH CARE FACILITIES

12.1 For the purpose of this standard, the health care facility's governing body shall determine the applicability of these criteria for determining full cylinders and containers.

12.2 Full cylinders and containers shall be stored in accordance with this section and shall be segregated from all others.

12.3 **Storage for nonflammable gases equal to or greater than 85 m3 (3000 ft3) at STP – Standard Temperature and Pressure - shall comply with:**

Locations for central supply systems and the storage of gases shall meet the following requirements:

- a) They shall be constructed with access to move cylinders, equipment, and so forth, in and out of the location on hand trucks.
- b) They shall be provided with lockable doors or gates or otherwise able to be secured.
- c) If outdoors, they shall be provided with an enclosure (e.g., wall or fencing) constructed of noncombustible materials.
- d) If outdoors and greater than 18.6 m² (200 ft²), they shall be provided with a minimum of two entry/exits.
- e) If outdoors, bulk cryogenic liquid systems shall be provided with a minimum of two entry/exits.
- f) If indoors, they shall have interior finishes of noncombustible or limited-combustible materials.
- g) If indoors, the room shall be separated from the rest of the building by walls and floors having a 1-hour fire

resistance rating with doors and other opening protectives having a 3/4-hour fire protection rating.

- h)* Fuel-fired equipment shall not be located in the room.
- i)* They shall be provided with racks, chains, or other fastenings to secure all cylinders from falling, whether connected, unconnected, full, or empty.
- j)* They shall be supplied with electrical power compliant with the requirements for essential electrical systems.
- k)* They shall protect electrical devices from physical damage
- l)* They shall allow access by delivery vehicles and management of cylinders.

12.4 Storage for nonflammable gases greater than 8.5 m³ (300 ft³), but less than 85 m³ (3000 ft³)

- a)* Storage locations shall be outdoors in an enclosure or within an enclosed interior space of noncombustible or limited-combustible construction, with doors (or gates outdoors) that can be secured against unauthorized entry.
- b)* Oxidizing gases such as oxygen and nitrous oxide shall not be stored with any flammable gas, liquid, or vapor and shall be separated from combustibles or flammable materials by one of the following:
 - i.* Minimum distance of 6.1 m (20 ft)
 - ii.* Minimum distance of 1.5 m (5 ft) if the entire storage location is protected by an automatic sprinkler system.
- c)* Cylinder and container storage locations shall comply with temperature limitations, and prevent from reaching temperatures in excess of 52°C(125°F).
- d)* Smoking, open flames, electric heating elements, and other sources of ignition shall be prohibited within storage locations and within 6.1 m (20 ft) of outside storage locations.

- e) Cylinder valve protection caps shall be in place when not in use.

12.5 Storage for nonflammable gases with a total volume equal to or less than 8.5 m³ (300 ft³)

- a) When small-size (A, B, D, or E) cylinders are in use, they shall be attached to a cylinder stand or to medical equipment designed to receive and hold compressed gas cylinders.
- b) Individual small-size (A, B, D, or E) cylinders available for immediate use in patient care spaces shall not be considered to be in storage.
- c) Cylinders shall not be chained to portable or movable apparatus such as beds and oxygen tents.

12.6 Signs

- a) Storage locations meeting the requirements shall have precautionary signage, readable from a distance of 1.5 m (5 ft), displayed on each door or gate of the storage room or enclosure.
- b) Sign(s) shall include the following wording as a minimum:
 - i. CAUTION
 - ii. OXIDIZING GAS(ES) STORED WITHIN
 - iii. NO SMOKING

Annex 1 (Informative): Images of Type E Valves and Hand Wheel Valves

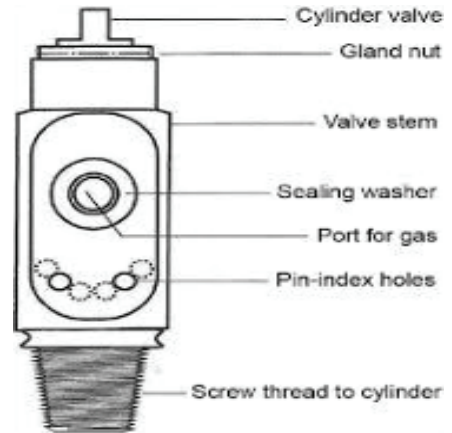
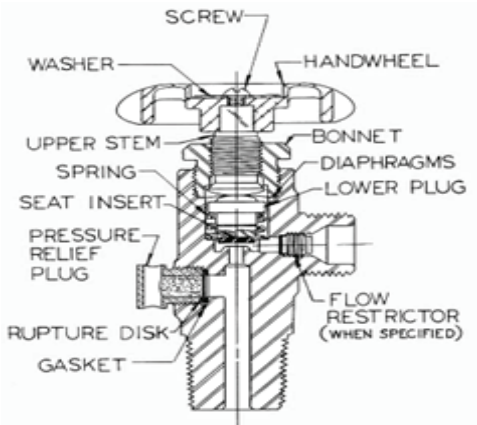

HAND WHEEL TYPE VALVES

POST-TYPE VALVES
(Type E) – Yoke

END OF DOCUMENT

MADE by the Minister responsible for the Bureau of Standards this 10th day of April, 2024.

(HON. JOSE ABELARDO MAI)

Minister of Agriculture, Food Security and Enterprise
(Minister responsible for the Bureau of Standards)