

**BELIZE:**

**STANDARDS (BELIZE STANDARDS SPECIFICATION  
FOR NITROGEN) (DECLARATION AS A COMPULSORY  
STANDARD) ORDER, 2024**

**ARRANGEMENT OF PARAGRAPHS**

1. Citation.
2. Declaration of Compulsory Standard.
3. Purpose of Compulsory Standard.
4. Commencement.

**SCHEDULE**

**BELIZE:**

**STATUTORY INSTRUMENT**

**No. 63 of 2024**

**ORDER** made by the Minister responsible for the Bureau of Standards, on the recommendation of the Belize Bureau of Standards, in exercise of powers conferred upon him by section 9(2) of the Standards Act, Chapter 295 of the Substantive Laws of Belize, Revised Edition 2020, and all other powers thereunto him enabling.

*(Gazetted 15th April, 2024).*

**WHEREAS**, section 9(3) of the Standards Act, Chapter 295 of the Laws of Belize provides that the Minister shall, by publication in the Gazette, give at least thirty days' notice of his intention to make an Order declaring a compulsory standard and shall thereby indicate the date on which it is intended that the compulsory standard shall come into force;

**AND WHEREAS**, a notice of intention to declare the **BELIZE SPECIFICATION FOR NITROGEN (BZS 33: 2024)** to be a compulsory standard was published in the Belize Gazette dated 13th January 2024;

**AND WHEREAS**, no objections have been received to the making of the said Order;

**NOW, THEREFORE, IT IS ORDERED** as follows:-

1. This Order may be cited as the

Citation.

**STANDARDS (BELIZE STANDARDS  
SPECIFICATION FOR NITROGEN)  
(DECLARATION AS A COMPULSORY STANDARD)  
ORDER, 2024.**

Declaration of  
Compulsory  
standard.  
Schedule.

2. The Belize Standard (BZS 33: 2024 SPECIFICATION FOR NITROGEN), the full text of which appears in the Schedule hereto, is hereby declared to be a compulsory standard.

Purpose of  
Compulsory  
Standard.

3. The standard referred to in paragraph 2 is intended primarily–

- (a) to protect the consumer or user against danger to health or safety;
- (b) to ensure quality in goods produced for home use or for export;
- (c) to prevent fraud or deception arising from misleading advertising or labelling; and
- (d) to require adequate information to be given to the consumer or user.

Commencement.

4. This Order shall come into effect on the 15th day of April 2024.

**SCHEDULE***[paragraph 2]***BEIZE STANDARD  
SPECIFICATION FOR NITROGEN**

---

**0 FOREWORD**

0.1 This standard provides a description of nitrogen characteristics, safety, storage and handling practices, when it is used for medical or industrial applications.

0.2 This standard is intended for compulsory implementation by nitrogen users, manufacturers and distributors.

0.3 Nitrogen is widely used in the food industry to prevent oxidative deterioration, mold growth, and insect infestation. Coffee, margarine, leafy vegetables, and meat are several foods in the long list of food products using nitrogen in processing or packaging. One of the largest uses of nitrogen is in the manufacture of ammonia where a mixture of three parts hydrogen and one part nitrogen constitutes the synthesis gas. In the chemical industry, nitrogen is used in many processes to exclude oxygen or moisture, or as a diluent. It is also widely used in polymerizations. In petroleum refining, nitrogen is used in the regeneration of spent reforming catalyst. Its uses in the semiconductor industry include purging, blanketing, pressurizing systems, and as a coolant fluid. It is also used as a carrier gas in chemical deposition.

0.4 In preparing this draft, assistance was received from the following documents:

- a) CGA G-10.1 - Commodity Specification for Nitrogen.
- b) USP 29 - United States Pharmacopeia and National Formulary (USP-NF).

- c) 21 CFR - Title 21 of the U.S. Code of Federal Regulations, (21 CFR) Part 3.
- d) CGA G-4 - Oxygen, Eleventh Edition (Compressed Gas Association).
- e) CGA P-9 - The Inert Gases: Argon, Nitrogen, and Helium.

## 1 SCOPE

- 1.1 This standard specifies minimum requirements for gaseous and liquid nitrogen obtained by the air liquefaction process, commonly used in medical and industrial applications.
- 1.2 This standard also provides requirements regarding nitrogen properties and safe handling practices.

## 2 NORMATIVE REFERENCES

The following referenced documents are indispensable for the application of this document. For dated references, only the edition cited applies. For undated references, the latest edition of the referenced document (including any amendments) applies.

- a) BZS 1: Part 8 - Belize Standard Specification for Labelling Part 8: Labelling and Marking of Medical Gas Cylinders.
- b) CGA G-10.1 - Commodity Specification for Nitrogen.
- c) CGA M-14 - Guideline for Liquid Oxygen and Liquid Nitrogen Bulk Transport Change of Grade.
- d) CGA P-2 - Guideline for Characteristics and Safe Handling of Medical Gases.
- e) CGA G-4.3 - Commodity Specification for Oxygen.

- f) CGA P-8.9 - Bulk Liquid Oxygen, Nitrogen and Argon Storage Systems at Production Sites.
- g) USP / NF 29 - United States Pharmacopeia and National Formulary.
- h) 21 CFR - Title 21 of the U.S. Code of Federal Regulations, (21 CFR) Part 3.
- i) 49 CFR - Title 49 of the U.S. Code of Federal Regulations (49 CFR) Parts 100-199.

### 3. TERMS AND DEFINITIONS

For the purpose of this standard, the following terms and definitions shall apply.

- 3.1 **Container** means a portable compressed gas cylinder and liquid container made in accordance with Title 49 of the U.S. Code of Federal Regulations (49 CFR) Parts 100-199.
- 3.2 **Lot** means an amount of a product produced during a specified period with the same characteristics, identified by a specific code.
- 3.3 **Pressure relief device** means a device consisting of a frangible disk designed to burst under excessive pressure, or a combination disk backed with fusible metal with a low melting point designed to melt and release the gas in case of fire.
- 3.4 **Quality Verification Level (QVL)** means a parameter that specifies the maximum amount of impurities (also termed limiting characteristics) that can be present.

### 4. GENERAL CHARACTERISTICS

#### 4.1 Description

- a) Nitrogen is an element that at atmospheric temperatures and pressures exists as a colorless, odorless, tasteless diatomic gas. Approximately four-fifths of the atmosphere is nitrogen (78.03% by volume).
- b) Nitrogen is nontoxic and chemically inert at ordinary pressure and temperature conditions. It is nonflammable and inhibits combustion. It can act as an asphyxiant by displacing the amount of oxygen necessary to support life.
- c) As a gas at ambient temperature, nitrogen is approximately 3% less dense than air. It can be cooled and compressed to a colorless liquid that under atmospheric pressure boils at  $-320\text{ }^{\circ}\text{F}$  ( $-196\text{ }^{\circ}\text{C}$ ). As a liquid (at normal boiling point), nitrogen is approximately 81% as heavy as water. When heated above its critical temperature of  $-232.4\text{ }^{\circ}\text{F}$  ( $-146.9\text{ }^{\circ}\text{C}$ ), nitrogen can exist only as a gas regardless of pressure.

## 4.2 Production

- a) Liquid nitrogen is produced by fractional distillation of liquefied air in air separation plants. The nitrogen product obtained is 99.99%+ pure. Gaseous nitrogen is generally obtained by vaporizing liquid nitrogen.
- b) Pressure Swing Absorption (PSA) and selective screen membrane technology are alternative methods of producing gaseous nitrogen on site at user locations. These prepackaged units process air and are designed to meet a wide range of flow and purity requirements.

## 4.3 Cryogenic temperatures

- a) The method of manufacturing nitrogen is by fractional distillation after the liquefaction of air. Improved efficiency in utilization has led to a

generally recognized industry standard of purity, which exceeds the 99% required by the United States Pharmacopeia and National Formulary (USP–NF).

- b) The products of a cryogenic air separation plant have associated hazards such as:
- i. Cryogenic injuries or burns resulting from skin contact with very cold vapor, liquid, or surfaces. Effects are similar to those of a heat burn. Severity varies with the temperature and time of exposure. Exposed or insufficiently protected parts of the body can stick to cold surfaces due to the rapid freezing of available moisture. Skin and flesh can be torn on removal;
  - ii. Risk of frostbite or hypothermia (general body and brain cooling) in a cold environment. In the case of frostbite, there can be a warning as the body sections freeze. As the body temperature drops, the first indications of hypothermia are bizarre or unusual behavior followed, often rapidly, by loss of consciousness;
  - iii. Respiratory problems caused by the inhalation of cold gas. Short-term exposure generally causes discomfort; however, prolonged inhalation can result in effects leading to serious illness such as pulmonary edema or pneumonia; and
  - iv. Cold gases that are heavier than air tend to settle and flow to low levels and can create a dense water vapor fog. Depending on topography and weather conditions, hazardous concentrations, reduced visibility, or both can occur at considerable distances from the point of discharge.



#### 4.4 Embrittlement of materials

- a) Many materials such as some carbon steels and plastics are brittle at very low temperatures and the use of appropriate materials for the prevailing service conditions is essential.
- b) Metals suitable for cryogenic temperatures include stainless steel and other austenitic steels (such as AISI 304 and 316), 9% nickel steel, copper and its alloys, and aluminum.

### 5. CLASSIFICATION

#### 5.1 Types

Nitrogen is classified according to its type and grade of quality. There are two types:

- 5.1.1 Type I: gaseous nitrogen.
- 5.1.2 Type II: liquid nitrogen.

#### 5.2 Typical uses

Table 1: Typical Uses for Nitrogen

Grade	Typical uses
B	Medical Nitrogen NF, Food  <i>NOTE: National Formulary (NF) requires an identity test for nitrogen by a method included in this standard.</i>
L	General industrial usage, process gases, inerting, heat treatment applications, beverage applications
M	High purity industrial uses, blanketing, heat treatment applications
Q	Analytical/Instrumentation applications
R	Semiconductor, purging

#### 5.3 Quality Verification Level

Table 1 presents the component maximum in parts per million (ppm [v/v]) unless otherwise stated for the quality verification levels (QVLs) of nitrogen. A blank indicates no maximum limiting characteristic. The absence of a value in a listed QVL does not imply that the limiting characteristic is or is not present, but merely indicates that the test is not required for compliance with the specification.

**Table 2: Directory of limiting characteristics of Nitrogen.**

<b>QVLs (grades)</b>					
<b>Maximums for gaseous and liquid nitrogen</b>					
<b>(Type I and II)</b>					
	<b>B<sup>1)</sup></b>	<b>L<sup>2)</sup></b>	<b>M</b>	<b>Q</b>	<b>R</b>
Nitrogen min. % <sup>3)</sup>	99.0	99.998	99.999	99.999	99.9987
Argon, neon, helium				5	
Carbon dioxide					1
Carbon monoxide	10			5	5
Hydrogen				1	2
Odor	None				
Oxygen	10 000	10	5	1	3
Total hydrocarbon content (as methane)			5	1	1
Water		4	2	2	1
Dew Point °F		-89	-97	-97	-105
°C		-67.2	-71.7	-71.7	-76.1

**NOTE(S):**

- 1 Units in ppm (v/v) unless otherwise stated.
- 1) Nitrogen used in food processing shall meet the Grade B requirements as well as any additional impurity limits or other requirements as specified in the Food Chemicals Codex [5].
- 2) Nitrogen used in beverage applications shall meet the Grade L requirements. Additional requirements may be agreed upon between the supplier and the

customer.

- 3) Unless otherwise stated, percent nitrogen includes trace quantities of neon, helium, and argon.

**WARNING:** Nitrogen can act as an asphyxiant by displacing the amount of oxygen necessary to support life.

## 5.4 Physical constants

**Table 3: Physical Constants of Nitrogen**

	U.S. Units	SI Units
Chemical symbol	N <sub>2</sub>	N <sub>2</sub>
Molecular weight	28.01	28.01
Density of the gas at 70 °F (21.1 °C) and 1 atm	0.072 lb/ft <sup>3</sup>	1.153 kg/m <sup>3</sup>
Specific gravity of the gas at 70 °F (21.1 °C) and 1 atm (air = 1)	0.967	0.967
Specific volume of the gas at 70 °F (21.1 °C) and 1 atm	13.89 ft <sup>3</sup> /lb	0.867 m <sup>3</sup> /kg
Boiling point at 1 atm	-320.4 °F	-195.8 °C
Density of the liquid at boiling point and 1 atm	50.47 lb/ft <sup>3</sup>	808.5 kg/m <sup>3</sup>
Weight of liquid at boiling point	6.747 lb/gal	808.5 kg/m <sup>3</sup>
Gas/liquid ratio—Gas at 70 °F (21.1 °C) and 1 atm, liquid at boiling point, vol/vol	696.5	696.5
Melting point at 1 atm	-345.8 °F	-209.9 °C
Critical temperature	-232.4 °F	-146.9 °C
Critical pressure	493 psia	3399 kPa, abs
Critical density	19.60 lb/ft <sup>3</sup>	314.0 kg/m <sup>3</sup>
Triple point at 1.81 psia (12.5 kPa, abs)	-346.0 °F	-210.0 °C
Latent heat of vaporization at boiling point	85.6 Btu/lb	199.1 kJ/kg
Latent heat of fusion at melting point	11.1 Btu/lb	25.8 kJ/kg
Specific heat of the gas at 70 °F (21.1 °C) and 1 atm		
<i>C</i>	0.249 Btu/(lb)(°F)	1.04
<i>p</i>	0.177 Btu/(lb)(°F)	kJ/(kg)(°C)
<i>C</i>		0.741
<i>v</i>		kJ/(kg)(°C)
Ratio of specific heats ( <i>C<sub>p</sub></i> / <i>C<sub>v</sub></i> )	1.41	1.41
Solubility in water, vol/vol at 32 °F (0 °C)	0.023	0.023

## 6. QUALITY VERIFICATION SYSTEM

## 6. QUALITY VERIFICATION SYSTEM

### 6.1 Production qualification tests

Production qualification tests are either a single analysis or series of analyses performed on the product to ensure the reliability of the production facility to supply nitrogen of the required QVL. This production qualification may be verified by the analytical records of product from the supplier; or, if required, by analyses of representative samples of the product from the facility at appropriate intervals as agreed upon between the supplier and the customer. Production qualification tests may be performed by the supplier or by a laboratory agreed upon between the supplier and the customer.

### 6.2 Analytical requirements of the production qualification tests

- a) Analytical requirements of the production qualification tests include the determination of all limiting characteristics of nitrogen.
- b) To comply with the General Notices requirements of the *U.S. Pharmacopeia* and *National Formulary (USP–NF)*, tests suitable for detecting the occurrence of other impurities, the presence of which is inconsistent with applicable manufacturing practice or good pharmaceutical practice, should be used in addition to the tests provided in the *U.S. Pharmacopeia (USP)* monograph.

### 6.3 Lot acceptance tests

Lot acceptance tests are analyses performed on the nitrogen in the shipping container or a sample thereof that is representative of the lot.

### 6.4 Lot definitions

Examples of a lot include, but are not limited to, the following:

- a) nitrogen supplied during a specific time period (for example, one continuous work shift, daily, weekly, etc.);
- b) nitrogen supplied in one shipment;
- c) nitrogen supplied in the container(s) filled on one manifold at the same time; and
- d) nitrogen supplied or containers filled during an uninterrupted filling sequence.

The quantity definitions may be used.

## 7 SAMPLING

### 7.1 Container sample size

The quantity of nitrogen in a single sample container should be sufficient to perform the analyses for the intended limiting characteristics. If a single sample does not contain a sufficient quantity of nitrogen to perform the intended analyses, additional samples from the same lot shall be taken under similar conditions.

### 7.2 Gaseous samples

- a) Gaseous samples shall be representative of the nitrogen supply. Samples shall be obtained in accordance with one of the following:
- b) By filling the sample container and delivery containers at the same time, on the same manifold, and in the same manner.
- c) By withdrawing a sample from the supply container through a suitable connection into the sample container.
- d) No regulator shall be used between the supply and the sample container (a suitable purge valve is permissible);

**CAUTION:** For safety reasons, the sample container and sampling system shall have a rated service pressure at least equal to the pressure in the supply container.

- e) By connecting the container being sampled directly to the analytical equipment using suitable pressure regulation to prevent over pressurizing this equipment; or
- f) By selecting a representative container from the containers filled in the lot.

### 7.3 Liquid samples

Liquid samples shall be representative of the liquid nitrogen supply. Samples shall be obtained by withdrawing a sample directly through an analytical filter system.

## 8 ANALYTICAL PROCEDURES

### 8.1 Parameters of analysis

The parameters for analytical techniques contained in this section are:

- a) percent (v/v) = parts per hundred by volume;
- b) ppm (v/v) = parts per million by volume;
- c) ppb (v/v) = parts per billion by volume;
- d) Water/dew point is expressed in ppm (v/v) and °F at 1 atm, abs (101 kPa, abs);
- e) For the purposes of this standard, THC (as methane) is defined as the single carbon atom equivalent;

- f) Calibration gas standards containing the applicable gaseous components are required to calibrate the analytical instruments used to determine the limiting characteristic levels of nitrogen;
- g) Analytical equipment shall be operated and properly calibrated in accordance with the manufacturer's instructions;
- h) Specific measurement of odor in oxygen is impractical. The presence of a pronounced odor should render the oxygen unsatisfactory;
- i) United States Pharmacopoeia and National Formulary (USP-NF) refers to the test requirements for nitrogen contained in the *USP NF*, which has nitrogen in the NF section; and
- j) Other analytical methods not listed in this specification are acceptable if agreed upon between the supplier and the customer.

## 8.2 Percent nitrogen

The percent nitrogen shall be determined by one of the following procedures:

- a) By determining the oxygen content by a gas chromatograph. This method can be used not only for the oxygen determination, but also for the determination of many limiting characteristic gaseous components. Appropriate impurity concentrating techniques may be used to attain the necessary sensitivity. The analyzer shall be calibrated at appropriate intervals by using calibration gas standards. The analyzers shall be operated in a manner to accurately measure the limiting characteristics as defined in Table 2.

- b) The percent nitrogen is the value obtained when this amount expressed as a percent (v/v) is subtracted from 100%;
- c) By determining the amount of the aggregate impurities using the methods in the following sections. The percent nitrogen is the value obtained when this amount expressed as percent (v/v) is subtracted from 100%;
- d) By determining the aggregate of all impurities by mass spectrometer. The percent nitrogen is the value obtained when the aggregate expressed as percent (v/v) is subtracted from 100%.

### 8.3 Water content

The water content shall be determined by using one of the following methods:

- a) Electrolytic hygrometer having an indicator graduated in ppm (v/v) on a range that is no greater than 10 times the specified maximum moisture content. The analyzer shall be operated in a manner to accurately measure the limiting characteristic as defined in Table 2;
- b) Dew point analyzer in which the temperature of a viewed surface is measured at the time moisture condensation first begins to form;
- c) Metal oxide capacitor equipped analyzer on a range that is no greater than 10 times the specified maximum moisture content. The analyzer shall be operated in a manner to accurately measure the limiting characteristic as defined in Table 2;
- d) Piezoelectric oscillating quartz crystal hygrometer. The analyzer shall be operated in a manner to accurately measure the limiting characteristic as defined in Table 1; or



- e) Infrared, tuneable diode laser or cavity ring down spectrometer using an appropriate spectral wavelength specific for moisture, operated in a manner to accurately measure the limiting characteristic as defined in Table 2.

#### 8.4 Total Hydrocarbon content

- a) Flame ionization-type analyzer. The analyzer shall be calibrated at appropriate intervals by using calibration gas standards having a nitrogen balance. The range used shall be no greater than 10 times the specified maximum THC expressed as methane. The analyzer shall be operated in a manner to accurately measure the limiting characteristics as defined in Table 2;
- b) Gas cell equipped infrared analyzer. The analyzer shall be calibrated at appropriate intervals by using calibration gas standards (see 8.1) at a wavelength of approximately 3.5 (the characteristic absorption wavelength for carbon-hydrogen [C-H] stretching). The analyzer shall be operated in a manner to accurately measure the limiting characteristic as defined in Table 2; or
- c) Gas chromatograph in accordance with 8.2.

#### 8.5 Oxygen content

The oxygen content shall be determined by using one of the following methods:

- a) Tungsten filament lamp-type analyzer. The analyzer shall be checked for proper operation at appropriate intervals by using a calibration gas standard (see 6.1);
- b) Paramagnetic-type analyzer. The analyzer shall be calibrated at appropriate intervals by using calibration gas standards (see 8.1). The range used shall be no

greater than 10 times the specified maximum oxygen content.

- c) Electrochemical-type oxygen analyzer containing solid or aqueous electrolyte. The analyzer shall be calibrated at appropriate intervals by using calibration gas standards (see 6.1) or integrally in accordance with Faraday's Law. The range used shall be no greater than 10 times the specified maximum oxygen content.
- d) Gas chromatograph in accordance with 6.2; or
- e) Mass spectrometer.
- f) Regardless of the analyzer chosen, it shall be operated in a manner to accurately measure the limiting characteristic as defined in Table 2.

## 8.6 Hydrogen content

The hydrogen content shall be determined by using one of the following methods:

- a) Gas chromatograph in accordance with 6.2; or
- b) Analyzer in which hydrogen reacts to form a compound that is subsequently measured. The analyzer shall be calibrated at appropriate intervals by using calibration gas standards (see 6.1). The range used shall be no greater than 10 times the specified maximum hydrogen content. The analyzer shall be operated in a manner to accurately measure the limiting characteristic as defined in Table 2.

## 8.7 Argon, helium and neon content

The argon, helium, and neon content shall be determined by a gas chromatograph in accordance with 8.2.

## 8.8 Carbon monoxide content

The carbon monoxide content shall be determined by using one of the following methods:

- a) Gas cell equipped infrared analyzer. The analyzer shall be calibrated at appropriate intervals by using calibration gas standards (see 8.1) at a wavelength of approximately 4.6 (the characteristic wavelength for carbon monoxide). The analyzer shall be operated in a manner to accurately measure the limiting characteristic as defined in Table 2;
- b) Gas chromatograph in accordance with 8.2;
- c) Apparatus using a detector tube filled with a color-reactive chemical. The degree of accuracy depends on the precision of the measurements and the analytical bias of the tube;
- d) Catalytic methanator gas chromatograph in accordance with 8.2; or
- e) Electrochemical fuel cell analyzer specific to carbon monoxide. The analyzer shall be calibrated at appropriate intervals by using calibration gas standards (see 8.1). The analyzer shall be operated in a manner to accurately measure the limiting characteristic as defined in Table 2.

## 8.9 Carbon dioxide content

The carbon dioxide content shall be determined by using one of the following methods:

- a) Apparatus using a detector tube filled with a color-reactive chemical. The degree of accuracy depends on the precision of the measurements and the analytical bias of the tube;

- b) Gas cell equipped infrared analyzer. The analyzer shall be calibrated at appropriate intervals by using calibration gas standards (see 8.1) at a wavelength of approximately 4.3 (the characteristic absorption wavelength for carbon dioxide). The analyzer shall be operated in a manner to accurately measure the limiting characteristic as defined in Table 2; or
- c) Gas chromatograph in accordance with 8.2.

### 8.10 Odor detection

Carefully open the container valve to produce a moderate flow of gas. Do not direct the gas stream toward the face, but deflect a portion of the stream toward the nose. No appreciable odor should be discernible. Refer to the USP NF [7].

**WARNING:** Nitrogen can act as an asphyxiant by displacing the amount of oxygen necessary to support life. For additional information, see CGA P-9 [4].

### 8.11 NF tests

NF tests shall be performed as specified in the *USP NF*.

### 8.12 Moisture conversion data

Water/dew point is expressed in ppm (v/v) and °F at 1 atm, abs (101 kPa, abs). To convert to other units, use Table 3.

Table 4: Moisture conversion data

Dew point °F	Dew point °C	Moisture content ppm (v/v)	Moisture content mg/L
-130	-90.0	0.1	0.00008
-120	-84.4	0.25	0.00020
-110	-78.9	0.63	0.00051
-105	-76.1	1.00	0.00080

-104	-75.6	1.08	0.00087
-103	-75.0	1.18	0.00095
-102	-74.4	1.29	0.00104
-101	-73.9	1.40	0.00113
-100	-73.3	1.53	0.00123
-99	-72.8	1.66	0.00133
-98	-72.2	1.81	0.00146
-97	-71.7	1.96	0.00158
-96	-71.1	2.15	0.00173
-95	-70.6	2.35	0.00189
-94	-70.0	2.54	0.00204
-93	-69.4	2.76	0.00222
-92	-68.9	3.00	0.00241
-91	-68.3	3.28	0.00264
-90	-67.8	3.53	0.00284
-89	-67.2	3.84	0.00309
-88	-66.7	4.15	0.00334
-87	-66.1	4.50	0.00362
-86	-65.6	4.78	0.00384
-85	-65.0	5.3	0.00426
-84	-64.4	5.7	0.00458
-83	-63.9	6.2	0.00498
-82	-63.3	6.6	0.00531
-81	-62.8	7.2	0.00579
-80	-62.2	7.8	0.00627
-79	-61.7	8.4	0.00675
-78	-61.1	9.1	0.00732
-77	-60.6	9.8	0.00788
-76	-60.0	10.5	0.00844
-75	-59.4	11.4	0.00917
-74	-58.9	12.3	0.00989
-73	-58.3	13.3	0.01069
-72	-57.8	14.3	0.01150
-71	-52.2	15.4	0.01238
-70	-56.7	16.6	0.01335
-69	-56.1	17.9	0.01439
-68	-55.6	19.2	0.01544
-67	-55.0	20.6	0.01656
-66	-54.4	22.1	0.01777
-65	-53.9	23.6	0.01897
-64	-53.3	25.6	0.02058
-63	-52.8	27.5	0.02211

-62	-52.2	29.4	0.02364
-61	-51.7	31.7	0.02549
-60	-51.1	34.0	0.02734
-59	-50.6	36.5	0.02935
-58	-50.0	39.0	0.03136
-57	-49.4	41.8	0.03361
-56	-48.9	44.6	0.03586
-55	-48.3	48.0	0.03859
-54	-47.8	51	0.04100
-53	-47.2	55	0.04220
-52	-46.7	59	0.04744
-51	-46.1	62	0.04985
-50	-45.6	67	0.05387
-49	-45.0	72	0.05789
-48	-44.4	76	0.06110
-47	-43.9	82	0.06593
-46	-43.3	87	0.06994
-45	-42.8	92	0.07397
-44	-42.2	98	0.07879
-43	-41.7	105	0.08442
-42	-41.1	113	0.09085
-41	-40.6	119	0.09568
-40	-40.0	128	0.10291
-39	-39.4	136	0.10934
-38	-38.9	144	0.11578
-37	-38.3	153	0.12301
-36	-37.8	164	0.13186
-35	-37.2	174	0.13990
-34	-36.7	185	0.14874
-33	-36.1	196	0.15758
-32	-35.6	210	0.16884
-31	-35.0	222	0.17849
-30	-34.4	235	0.18894
-29	-33.9	250	0.20100
-28	-33.3	265	0.21306
-27	-32.8	283	0.22753
-26	-32.2	300	0.24120
-25	-31.7	317	0.25487
-24	-31.1	338	0.27175
-23	-30.6	358	0.28783
-22	-30.0	378	0.30391
-21	-29.4	400	0.32160

-20	-28.9	422	0.33929
-19	-28.3	448	0.36019
-18	-27.8	475	0.38190
-17	-27.2	500	0.40200
-16	-26.7	530	0.42612
-15	-26.1	560	0.45024
-14	-25.6	590	0.47436
-13	-25.0	630	0.50652
-12	-24.4	660	0.53064
-11	-23.9	700	0.56280
-10	-23.3	740	0.59496
-9	-22.8	780	0.62712
-8	-22.2	820	0.65928
-7	-21.7	870	0.69948
-6	-21.1	920	0.73968
-5	-20.6	970	0.77988
-4	-20.0	1020	0.82008
0	-17.8	1270	1.02108

## 9 CONTAINERS

### 9.1 Nitrogen container preparation

Container preparation shall be in accordance with an acceptable technique that encompasses evacuation and cleaning or purging procedures to ensure that the containers, closures, and other component parts are suitable for their intended use. That is, the containers shall be prepared so that they are not reactive, additive, or absorptive to an extent that significantly affects the identity, strength, quality, or purity of the nitrogen and furnishes adequate protection against its deterioration or contamination.

### 9.2 Nitrogen NF

Nitrogen NF is classified as a drug and shall be labeled in accordance with the appropriate food and drug regulations.

### 9.3 Valves on nitrogen containers

- a) Container valve connections that do not fit shall not be used. Threads on regulator connections or other auxiliary requirements shall match those on the container valve outlet. The valve outlet connection shall conform to recognized standards.
- b) The threads on a cylinder valve outlet, as well as on regulators and other ancillary equipment, shall be examined prior to connection to ensure they are clean and undamaged.

**Table 5: Valve connection for Nitrogen Cylinder and Containers**

Oxygen Gas rating	CGA Standard
Up to 3000 psi (20 680 kPa) Threaded	580, 580R
(Type E) Yoke	960
Oil-tolerant 3001 to 4700 psi (20 690 to 32 400 kPa)	621
3001 to 4700 psi (20 690 to 32 400 kPa)	680, 680R
4701 to 6400 psi (32 410 to 44 100 kPa)	677
Cryogenic liquid withdrawal and fill connection	295
Liquid cylinder vent connection	295
Ultra-high integrity	718

#### 9.4 Pressure relief devices

- a) A pressure relief device is a pressure and/or temperature-activated device used to prevent the pressure in a normally charged cylinder from rising above a predetermined maximum, thereby preventing rupture of the cylinder when subjected to a standard fire test as required by 49 CFR 173.301(f)(1) or clause 4.3.2 of CSA B340 as adopted by 5.10(1) of the TC regulations [1, 2, 4].
- b) Oxygen cylinders are required to be equipped with pressure relief devices. Cryogenic vessels may be



equipped with spring-loaded pressure relief valves that reseal when the pressure drops to a preselected value.

- c) A Type CG-1 PRD is a rupture disk device that functions by inlet static pressure actuating the rupture disk by bursting in tension or shear at a predetermined pressure to permit the discharge of gas.
- d) When a rupture disk device is used as a PRD on a compressed gas cylinder, the rated burst pressure of the disk when tested at the specified design temperature within the range of 60F to 160F (15.6C to 71.1C) shall not exceed the minimum required test pressure of the cylinder with which the disk is used.

## 9.5 Filling limits

- a) Because of the characteristics of any gas confined in a closed container to increase in pressure with rising temperature, the possibility always exists that a cylinder charged with gas at a safe pressure at normal temperature could reach a dangerously high pressure at high temperatures. To prevent this with normal usage, regulations limit the amount of gas that may be charged into a cylinder.
- b) TC/DOT-3A, TC/DOT-3AA, TC/DOT-3AL, and TC/DOT-39 cylinders shall not be filled to a pressure greater than the stamped service pressure at 70 °F (21.1 °C). TC/DOT-3A and TC/DOT-3AA cylinders stamped with a plus mark (+) after the last test date may be filled to a pressure 10% greater than the stamped service pressure.
- c) At pressures greater than 25.3 psi (174 kPa), TC/DOT-4L cylinders shall be filled by weight.

## 9.6 Retesting

- a) Specification 3A, 3AA, and 3AL cylinders, UN and ISO receptacles shall be periodically retested. Periodic

retesting of Specification 4L welded insulated liquid cylinders is not required. Specification 39 cylinders shall not be refilled and hence require no retest. Retesting of 3E cylinders is not required. Cylinder retesting shall be performed only by DOT authorized retesters holding a valid RIN as prescribed in 49 CFR parts 100 – 199.

- b) Cylinders that have been in a fire shall be removed from service and shall not be returned to service. Specification 3AL cylinders that are exposed to fire or temperatures above 350 °F (177 °C) shall be removed from service and condemned. Specification 4L cylinders that are in a fire shall be removed from service and condemned.
- c) Cylinders showing any type of damage that jeopardizes their integrity and the safe transportation of the gas or liquid content, shall be removed from service, and condemned.
- d) Records shall be kept giving data showing the results of the tests made on all cylinders, and each cylinder passing the test shall be plainly and permanently stamped with the month and year of the test as well as the retester's identification number. Dates of previous tests shall not be obliterated.
- e) Cylinder marking shall comply with DOT requirements established in 49 CFR, and shall not be removed or changed, except as provided in applicable regulations.

## 9.7 Labelling

- a) Nitrogen manufactured, imported, sold or offered for sale in containers shall comply with the Belize Standard Specification for Labelling Part 8: Labelling and Marking of Medical Gas Cylinders.

- b) In addition to marking of the proper shipping name and identification number on a cylinder, a 100 mm (3.9 in) diamond (square-on-point) green label (designating a nonflammable gas) having the number 2 in the lower corner and be attached to each cylinder containing oxygen when transported by common carrier.

## 9.8 Tank cars

- a) High pressure gaseous nitrogen may be transported in tank cars complying with the safety practices related to gas industry.
- b) Liquefied inert gases are transported specially designed tank cars at low pressure (less than 40 psi). Under these conditions, required hazardous materials shipping papers and container markings.
- c) Shipping papers shall include proper shipping name.
- d) Marking the container with the proper DOT/TC and identification number, and incident reporting method shall be considered according to emergency response guidebook information.

## 10 HIGH PRESSURE INERT GAS CYLINDERS

### 10.1 Guidelines for safe storage

- a) Cylinders should be stored in a designated location;
- b) Cylinders shall not be placed near flammable material, especially oil, grease, or any other readily combustible substance;
- c) Cylinders should not be stored above 125 °F (51.7 °C). Cylinders should never be allowed to reach a temperature exceeding 125 °F (51.7 °C) because of the rise in pressure in the cylinder with increasing temperature. Therefore, cylinders should never be

placed near furnaces, radiators, or any other source of heat;

- d)* Cylinders should be protected from abnormal mechanical shock, which is liable to damage the cylinder, valve, or pressure relief device;
- e)* Cylinders shall be protected from heavy moving objects striking them or falling on them;
- f)* Cylinders shall not be stored in areas (i.e., elevators, gangways, etc.) where the cylinders can fall more than half of their height;
- g)* Cylinders in storage shall be stored standing upright where they are not likely to be knocked over, or the cylinders shall be secured;
- h)* Small cylinders may be stored in a horizontal position if the cylinder is installed in a holder or cradle designed to secure the cylinder;
- i)* Valve protection caps, when provided, shall be in place and fastened hand-tight, except when cylinders are in use or connected for use;
- j)* Cylinders should be protected from tampering;
- k)* Empty and full cylinders should be stored separately and empty cylinders should be marked to avoid confusion;
- l)* Cylinders should be stored in dry, well-ventilated locations to prevent accidental movement;
- m)* Cylinders should not be stored near salt or other corrosive chemicals or fumes. Rusting will damage the cylinders and can cause the valve protection caps to stick;

- n) Cylinders should be stored on a suitable foundation such as concrete or steel grating; and
- o) Valves shall be closed on all cylinders not in use.

## 10.2 Guidelines for safe handling

- a) Cylinders shall only be filled by a certified supplier;
- b) Never tamper with, attempt to repair, paint, or alter cylinders, valves, or Pressure relief devices. Polishing and cleaning agents should never be applied to the valve since they can contain chemicals not compatible with the valve material or the gas in the cylinder;
- c) Cylinders shall not be placed where they can become part of an electric circuit. When electric welding, precautions shall be taken to prevent striking an arc against a cylinder;
- d) Markings stamped on cylinders shall not be tampered with except as provided by DOT authorized requalifier;
- e) Markings used for the identification of contents of cylinders shall not be defaced or removed. This applies to labels, decals, tags, stenciled marks, and the diamond-shaped yellow label, if attached;
- f) Notify the owner of the cylinder giving details and the cylinder number if any condition occurs that allows a foreign substance to enter the cylinder or valve;
- g) Cylinders shall not be used as rollers, supports, or for any purpose other than as intended by the supplier;
- h) It is sometimes necessary to move cylinders by crane or derrick using a platform, cage, or cradle to protect the cylinders from damage and keeps them from falling out;

- i) A suitable hand truck should be used with the container properly secured to the device;
- j) Cylinders shall not be transported lying horizontally on forklift trucks with valves overhanging in a position to collide with stationary objects. Whenever a forklift is used to transport cylinders, the cylinders shall be secured to prevent them from falling off;
- k) Cylinders shall not be dragged from place to place;
- l) Valves shall always be closed and protective caps shall be in place when appropriate before cylinders are moved;
- m) Cylinders should not be transported in the trunks of automobiles. They should be transported upright and secured properly;
- n) Cylinders may be transported and used in a horizontal position in ambulances and emergency vehicles if the cylinder is installed in a holder or cradle that is designed to secure the cylinder and protect the valve and regulator; and
- o) Small cylinders, such as those used in medical applications, are not equipped with valve protection caps or guards. These cylinders are susceptible to valve damage if dropped. Special precautions shall be taken when handling these types of cylinders. If a cylinder is dropped and the valve is damaged, the cylinder should be returned to the supplier unused. Damaged valves should be replaced before refilling.

### 10.3 Guidelines for safe use

- a) Use only cylinders marked in accordance with applicable DOT, UN or ISO regulations or standards;
- b) Compressed gases should be handled only by experienced and trained persons. The user shall first

- identify the product within the cylinder from the label or stencil on the cylinder before use.
- c) If the cylinder is not labeled to show the product contained, return the cylinder to the supplier unused.
  - d) Ensure that there is no oil or grease on hands or gloves, cylinders, valves, regulators, gauges, and fittings.

## 11 LIQUIFIED INERT GASES

### 11.1 Guidelines for safe storage, handling and use

- a) Any area in which a liquefied inert gas is used or stored should be properly ventilated. A person working in an area where the air has become enriched with argon, nitrogen, or helium can become unconscious without sensing the lack of oxygen. Remove the victim to fresh air. When necessary, perform artificial respiration and get medical assistance. Never dispose of a liquefied inert gas in an indoor work or storage area.
- b) Because of the extreme low temperatures of liquefied inert gases, the physical properties of materials with which they come in contact are apt to be greatly altered. This fact shall be considered wherever liquefied inert gases are handled.
- c) Severe burns can result if a liquefied inert gas remains in contact with the skin for more than a few seconds. Burns also result if contact is made for any length of time with uninsulated pipe or vessels containing a liquefied inert gas. In such cases, flood the skin area with large quantities of unheated water. If the skin becomes blistered or the eyes are affected, obtain medical treatment promptly. Adequate personal protective equipment (PPE) should be worn.

- d) Although the inert gases are used mostly in gaseous form, large quantities are shipped as liquid for distribution convenience and economy. At the use point, the liquid can be transferred into a storage unit and subsequently converted to gas for use or it can be converted into gaseous form before storage. See Section 14. The equivalent of 1 ft<sup>3</sup> (28.32 L) of liquid at the normal boiling point is 841.2 scf (23.82 m<sup>3</sup>) argon, 696.5 scf (19.69 m<sup>3</sup>) nitrogen, or 754.2 scf (21.36 m<sup>3</sup>) helium.
- e) The liquid is stored and shipped in specially designed, well-insulated containers that maintain the pressure of the vapor above the liquid at atmospheric pressure or at a low positive pressure. The temperature of the liquid will remain at or near its normal boiling point and any heat leak into the container will not alter the temperature if the container is vented to permit vaporized product to escape.
- f) Never attempt to transfer liquefied inert gas into a container or vessel that has not been specifically designed for that product. Containers used in shipment, storage, and transfer of cryogenic liquids are fabricated from materials that are able to withstand impact shock at low temperature as well as sustain the thermal stress created by extreme temperature changes during the cooldown period.
- g) Liquefied inert gases should be transported only in suitable containers that permit the escape of vapors to control the pressure that can build up in the containers. Concentration of the vapor should be prevented by ample ventilation since argon-, nitrogen-, or helium-enriched atmospheres can cause asphyxiation.
- h) Cryogenic liquid containers shall be provided with PRDs to ensure that the maximum design pressure of the vessel is not exceeded. Portable containers such as small dewars or flasks are to be vented to the atmosphere, and the vents should be inspected



periodically to ensure the vent port has not become bridged with ice formed by condensing moisture from the air.

- i)* Equipment used in liquefied inert gas distribution is usually determined by the user's requirements. See Section 14. Users should be instructed by suppliers in the proper use and operation of the supply or storage unit, and these instructions should be carefully followed.
- j)* A liquefied inert gas should be handled or used only by personnel instructed on the hazards of the material. Users should first verify the product's identity from a label or stencil on the cylinder. If the cylinder is not labeled to show what product is contained, return the cylinder to the supplier unused.
- k)* Equipment used in liquefied inert gas service should always be kept clean.
- l)* Metals used for liquefied inert gas equipment shall have satisfactory physical properties at the low operating temperatures. Ordinary carbon steels lose ductility at liquid inert gas temperatures and are considered too brittle for this service. Some suitable materials are austenitic chromium-nickel steels, 9% nickel steel, copper, copper-silicon alloys, aluminum, Monel metal, and some brasses and bronzes.
- m)* A small quantity of liquid produces large volumes of vaporized gas at atmospheric pressure. Therefore, all storage containers should be provided with PRDs unless containers such as small vacuum bottles or flasks are vented to the atmosphere.
- n)* All pipelines or vessels in which liquefied inert gases can be trapped between closed valves shall be equipped with PRDs. In cases where liquefied inert gas can be trapped in any valve cavity, means of venting shall be provided.

## 11.2 Handling liquefied inert gases in transfer systems or in open containers

- a) Because of their extremely low temperatures, liquefied inert gases should never be allowed to come in contact with the skin or with clothing worn directly on the skin. Prolonged contact can produce an effect on the skin similar to that of a burn. Contact with the cold walls of an uninsulated pipe or vessel can cause skin damage. Full-face shields, gloves, and aprons should be worn. Leather gloves loose enough to permit quick removal are recommended. High-top shoes with trousers worn outside the shoes are desirable. Any clothing that is splashed with liquefied gas should be immediately removed. If liquid does contact the skin, immediately flood the skin area with large quantities of unheated water. If the skin is blistered or the eyes are affected, obtain medical treatment promptly.
- b) Always handle liquefied inert gases in well-ventilated areas. During liquid transfer operations, large volumes of gas are emitted and can accumulate in the immediate area. Breathing argon-, nitrogen-, or helium-enriched air can cause asphyxiation.
- c) Spillage of liquefied inert gas can result in an asphyxiation hazard because a small amount of liquid can lead to the formation of a large amount of gas. Consequently, liquid spillage can rapidly cause oxygen deficiency in confined spaces and pits.
- d) Removal of cold gas from large vessels and deep pits can be difficult due to the relatively high density of the cold gas compared with air. The fact that air introduced into the bottom of such spaces tends to float up through the dense gas without displacing it presents a special problem because purging is liable to take much longer than expected. It can be more

effective to evacuate the gas from the bottom of the space.

- e) When transferring a liquefied inert gas from one container to another, the receiving container should be cooled gradually to prevent thermal shock. The vapors of the liquefied gas being transferred should always be vented to the atmosphere and high concentrations of escaping inert gas should not be allowed to collect. A liquid inert gas should be transferred only into a clean, empty container designed for cryogenic service.
- f) Introduction of a substance that is at normal room temperature into a liquid of such extremely low temperature as a liquefied inert gas is hazardous. There is a violent evolution of gas and there is likely to be considerable splashing of liquid. Individuals doing this work should be instructed in the hazard and should always wear a full-face shield and protective clothing.
- g) The use of liquefied inert gases may require other precautions to be taken. Each new use of liquid argon, nitrogen, and helium should be considered carefully and before instituted, safety precautions should be completely outlined. For instance, a small amount of liquefied inert gas can be frequently handled in a glass dewar flask. The flask occasionally collapses, particularly if the liquefied gas is splashed on the joint at the neck. These flasks should always be kept behind protective screens while in use.
- h) Small containers vented to the atmosphere should be inspected periodically to ensure that the vent has not become plugged, which can occur from condensation and freezing of atmospheric water vapor.

## 12 STORING, HANDLING, AND USING LIQUIFIED INERT GAS CYLINDERS

### 12.1 General

- a) Liquefied inert gas cylinders are double-walled pressure vessels usually 3 gallons (11.3 L) capacity or greater and should not be confused with double-walled atmospheric pressure liquid containers commonly referred to as dewars.
- b) Liquid nitrogen at a pressure of 25.3 psi or greater is classified as compressed gas and shall be packaged and shipped as prescribed here.
- c) The liquid cylinders normally operate at pressures above 25.3 psi so they shall be designed, constructed, and tested accordingly.

## 12.2 Storage and use of cylinders

- a) Before using inert gases, the user should read and understand all the labels and the SDS.
- b) Liquid cylinders shall be stored in a well-ventilated area, preferably outdoors. Heat leak into liquid cylinders will gradually increase the internal pressure of a cylinder not in use until the relief valve setting is reached. Vapor will then be vented, creating a possible oxygen-deficient atmosphere if the area is not well ventilated.
- c) Liquefied inert gas cylinders shall not be stored near flammable or combustible materials.
- d) Liquefied inert gas cylinders are dependent upon the vacuum in the insulation space between the double walls to provide the required degree of insulation. If this vacuum is lost, excessive amounts of gaseous product can vent through the PRDs. In this case, move the cylinder outdoors and notify the cylinder supplier.
- e) When using a liquefied inert gas cylinder, only regulators, valves, hoses, or other equipment designed and conditioned for that particular service should be

used. If the cylinder is not labeled to show the product contained, return the cylinder to supplier unused.

- f) Some liquefied inert gas cylinders contain vaporizing and superheating coils in the insulation space to provide gaseous product at near ambient temperature to the user. Should the use rate be excessive, the outer shell of the cylinder will frost heavily and the gaseous product can be extremely cold.
- g) A liquefied inert gas cylinder is equipped with a filling valve, a product withdrawal valve, a vent valve, a pressure gauge, a liquid level gage, and various regulators and PRDs. The product withdrawal valve is the only device used by the user, who should not operate or adjust any other device.

### 12.3 Disposition of empty cylinders

When liquid inert gas cylinders are emptied, the following procedure should be followed to ensure their prompt return to the supplier:

- a) Close all valves and replace all outlet protection devices; and
- b) Return the cylinder promptly to the supplier in accordance with their instructions.

## 13 BULK INERT GAS SYSTEMS

Large industrial and institutional users of argon, nitrogen, and helium need storage units on their premises with greater capacity than that provided by manifolded cylinders. Bulk storage systems consist of an assembly of equipment including storage containers, pressure regulators, PRDs, vaporizers, manifolds, and interconnecting piping. The inert gases may be stored as a gas or a liquid.

**Annex 1 (Informative): Images of Type E Valves and Hand Wheel Valves**

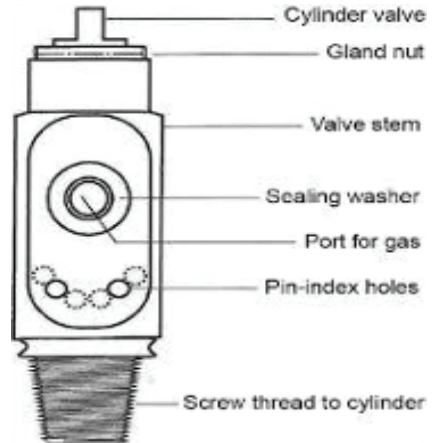
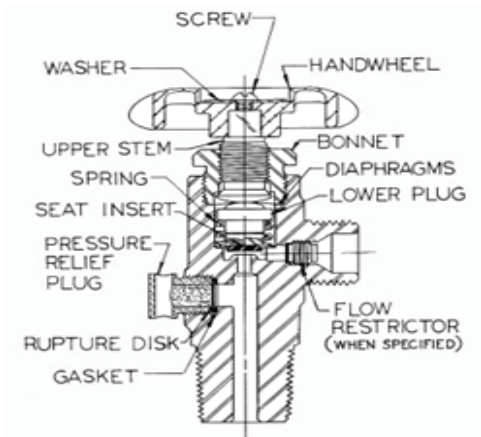

HAND WHEEL TYPE VALVES

POST-TYPE VALVES  
(Type E) – Yoke

END OF DOCUMENT

**MADE** by the Minister responsible for the Bureau of Standards this 10th day of April, 2024.

**(HON. JOSE ABELARDO MAI)**  
Minister of Agriculture, Food Security and Enterprise  
*(Minister responsible for the Bureau of Standards)*